

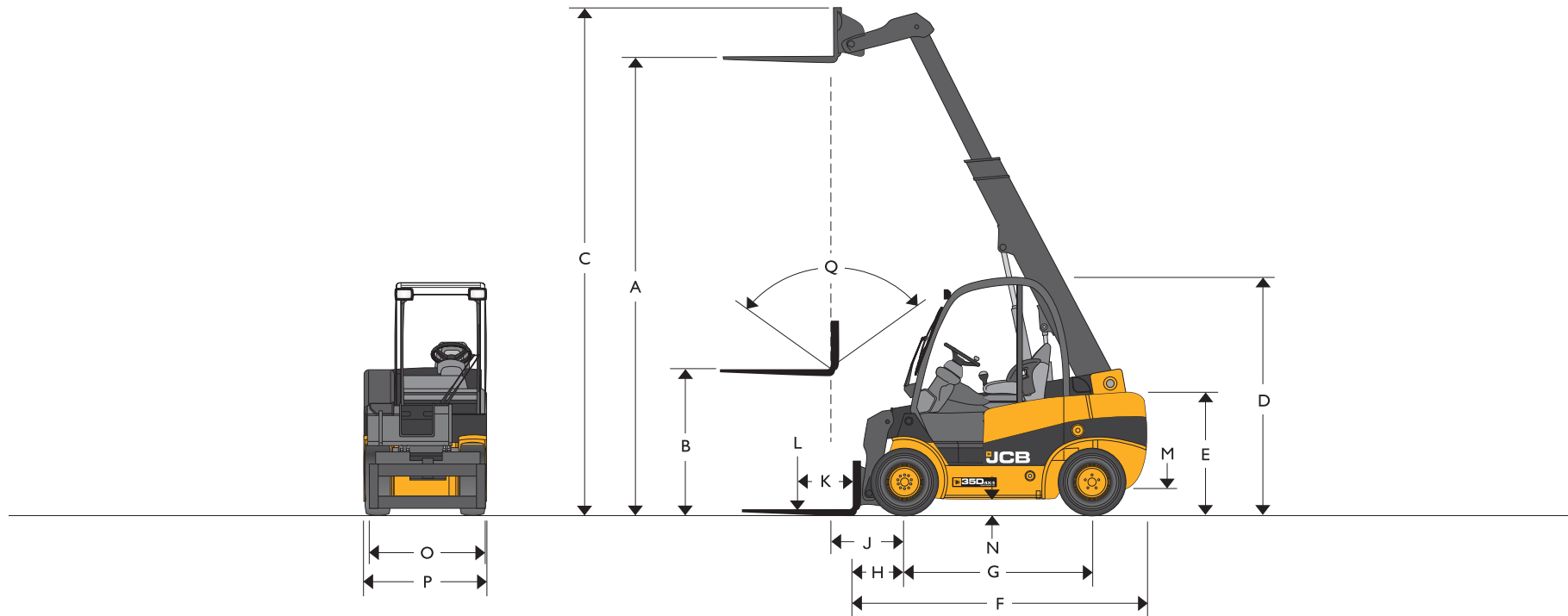

ENGINE FUEL TYPE: DIESEL LIFT CAPACITY: UP TO 3.5 TONNES



### STATIC DIMENSIONS

Model	TLT30D 4x4	TLT35D 4x4	Model	TLT30D 4x4	TLT35D 4x4		
A Lift height	mm	4000	4350	J Distance from c/l of front axle to fork face	mm	715	760
B Free lift (standard)	mm	1560	1350	K Load centre throughout the lift envelope	mm	500	500
C Height boom extended	mm	4805	5150	L Lift capacities (with sideshift)	kg	3000	3500
D Height of overhead guard (std/low)	mm	2300/2200	2300/2200	M Ground clearance (lowest point)	mm	165	175
E Height of operator's seat (std/low)	mm	1241/1221	1250/1230	N Ground clearance wheelbase centre	mm	192	175
F Length to fork face	mm	2840	3200	O Fork carriage width	mm	1200	1200
G Wheelbase	mm	1780	2050	P Maximum width of machine	mm	1400	1400
H Distance from c/l of front axle to fork face	mm	565	610	Q Carriage tilt total* F/B variable through lift arc	degrees	111	111



## GENERAL SPECIFICATION

Model	TLT30D 4x4	TLT35D 4x4	
Engine type	Diesel	Diesel	
Engine manufacture	JCB	Deutz	
Engine model	D-404-2.2	201 I-L04W	
Engine output (gross power)	kW	35.6	46
Engine – rated rpm		2600	2600
Engine – number of cylinders		4	4
Engine – cubic capacity	cm <sup>3</sup>	2200	3620
Working pressure for attachments	bar	170	170
Oil flow for attachments	l/min	70	70
Maximum reach ground level (500mm load centre)	mm	2230	2400
Maximum reach boom horizontal (500mm load centre)	mm	2390	2450
Turning radius	mm	2995	3500
Aisle width 90° stacking 800 x 1200/1000 x 1200	mm	4510/4710	5060/5260
Weight unladen	kg	5100	5500
Travel speeds	km/h	10/20	10/18
Gradeability (laden/unladen)	%	30 : 28	25 : 23
Transmission		TCR	TCR
Park brake type		Hand	Hand
Shovel rated capacity	m <sup>3</sup>	0.6	0.6
Shovel struck capacity	m <sup>3</sup>	0.5	0.5
Shovel dump height (30°)	mm	2550	2680
Shovel rollback angle at ground	degrees	37	33
Shovel width	mm	1385	1385
Tyre size front (standard) pneumatic		27 x 10-12	27 x 10-12
Tyre size rear (standard) pneumatic		27 x 10-12	27 x 10-12
Diesel tank capacity	litres	44	55

## STANDARD FEATURES

- All wheel drive with selectable traction control.
- Two drive modes for general work and gradient.
- Information display centre (I.D.C) complete with warning lights, hourmeter, diesel fuel gauge.
- Excellent turning radius and good ground clearance.
- Short overall length.
- JCB 'TCR' torque converter response transmission.
- 111 degree carriage tilt.
- Superb forward visibility.
- Comfortable operator's enclosure (structure fully meets international safety standards for (ROPS) Roll-Over Protection and (FOPS) Falling Object Protection).
- Seat belt and hip restraint on fully adjustable seat.
- Adaptive Load Control (Dependant on region).
- Self levelling forks.
- Hose-burst-check valves on tilt, lift, and extension ram circuits.
- Front screen guard.
- Excellent service access to major components.
- Battery isolator.
- Working lights front and rear.

## OPTIONS

Over 100 build options, including:

- Choice of pneumatic or foam filled tyres.
- Lightweight re-handling shovel.
- 'Trapdoor' shovel for loading/filling big bags in single operation.
- Quick disconnect system for easy changing between attachments.
- Sideshift carriage and various forks.
- Range of load guards, attachments, exhaust purification systems, etc.
- Various operator environments: safety mesh to operator's right, glazing to front/rear/top. Full cab with door and heater.
- Vinyl or fabric seat in high/low versions.
- Roadlights.

## LIFT CAPACITIES

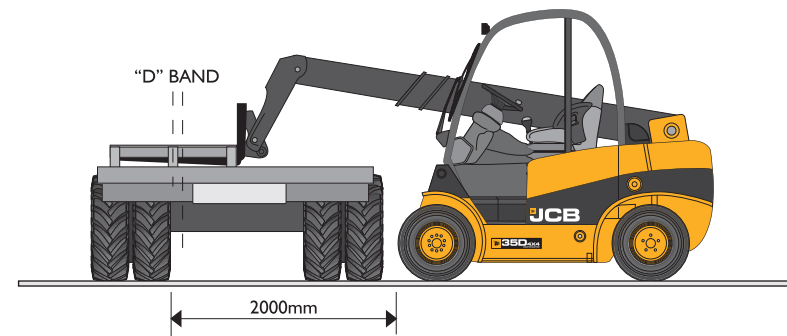
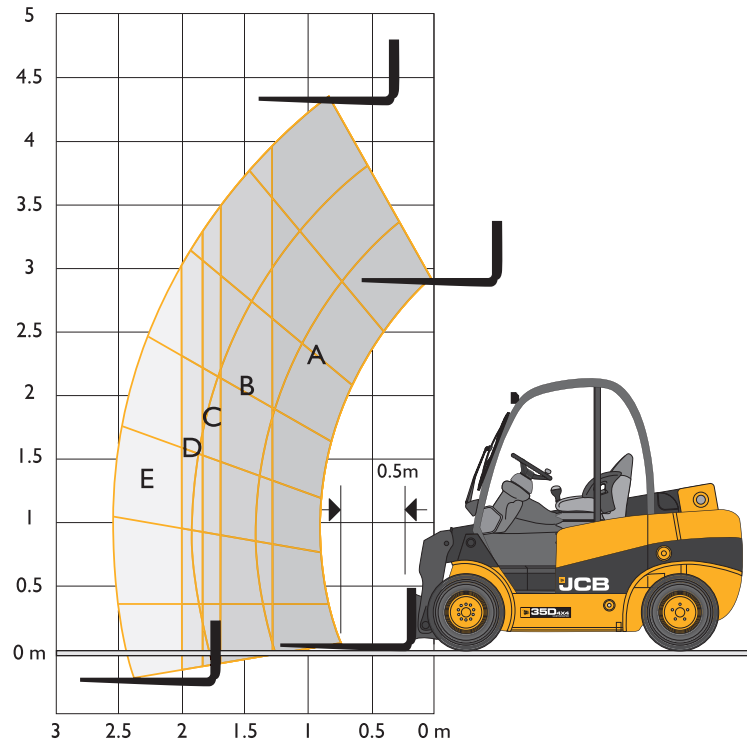

Capacity bands	TLT 30D 4x4
A	3000kg
B	2750kg
C	2500kg
D	2000kg
E	1500kg